



Inerter™ Liquid Nitrogen Dosing

The Inerter™ is a large volume liquid nitrogen (LN₂) dosing system for full container and high-volume headspace inerting applications. Chart engineers designed an ultra-efficient system to dispense a precise dose of LN₂ into every container every time to displace the oxygen in the container. When compared to traditional gaseous nitrogen flushing applications, the Inerter provides better consistency and reduces LN₂ consumption and cost.

Features

- **Compact Size** – enables installation in limited spaces
- **Precise Dosing** – delivers consistent, accurate dosing
- **Discrete Dosing*** – up to 2000 containers per minute
- **Discrete or Continuous Dosing** – change over defined by user
- **Vacuum Insulated Technology** – the most efficient use of LN₂
- **RemoteDose™ Capable*** – monitor and troubleshoot the system remotely thereby minimizing or eliminating system downtime**
- **IntelliDose™ Capable** – automatic dose adjustments at any line speed between low/high points as defined by user
- **Warranty** – two (2) year warranty against manufacturing defects from time of shipment

* When paired with the 2K controller. Results achieved at Chart laboratory conditions.

** Access to the internal network is necessary for this function.



How it Works

LN₂ is supplied to the Inerter by a vacuum insulated flex pipe from a Chart Phase Separator and flows into the dosing head. A 24vdc PNP sensor detects the speed of the line (encoder compatible); a second 24vdc PNP sensor detects the presence of a container. When a container is detected, the dosing head opens and dispenses an exact amount of pure LN₂ gasifies and escapes with oxygen to inert the headspace.

Key Benefits

- **Oxygen Reduction** – create an inert environment to preserve product freshness
- **Extend Shelf Life** – minimize oxygen levels
- **Reduce Nitrogen Consumption** – measurable and repeatable liquid doses
- **Lightweight PET** – reduce the weight of PET for cost and environmental savings
- **Glass to PET Transition** – eliminate glass safety hazards and weight of containers
- **Bottle Rigidity** – maintain bottle shape even with lighter weight containers
- **Eliminate Paneling** – increase the internal pressure to offset paneling issues
- **Stabilize Organic Products** – extend shelf life without preservatives
- **Ease of Labeling** – consistent bottle rigidity creates an efficient labeling process
- **Maximize Warehouse Storage Space** – increasing product stackability utilizes less square footage



Inerter™ Technical Specifications



Materials	Stainless Steel Series 300*
Weight	8 lbs (3.6 kg)
Body Dimensions	14"H x 2.5"W (406 x 64 mm)
Dosing Head Dimensions	9.5"H x 2"W (241 x 50.8 mm)
Arm Reach	6.5" (165 mm)
Head Pressure	Dependent on elevation of Phase Separator** 3 ft (914.4 mm) elevation height = ~1 psi (0.07 bar)
Nozzles	Ships with 0.040", 0.050", 0.060" 0.020" - 0.100" (0.005" increments) available
System Utilities	LN₂ : Max. 125 psi (8.62 bar); 80 psi (5.52 bar) optimal GN₂ : 60 - 100 psi (4.1 - 6.9 bar) Electricity : 110 - 240VAC; 50/60Hz, 110W
Steady State Consumption	0.04 gal (0.15 liter) / hour
EP Head Compatible	Yes
Quick Service Feature	No
Vacuum Insulated	Yes
Flexible Arm	No
SoftDose™ Compatible	Yes

Inerter™ Dimensions

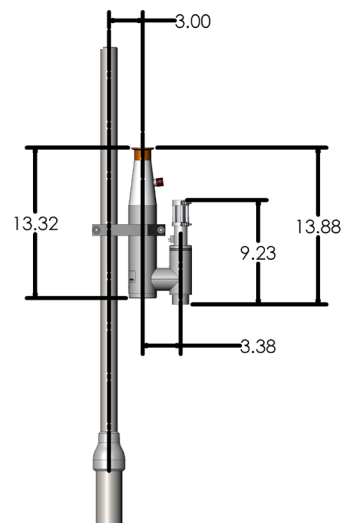

* 304 standard, 316L available upon request

** Phase Separator sold separately.

Controller Technical Specifications

Model	2K	500S	150S
PLC Platform	Allen-Bradley or Siemens	Siemens	Siemens
Display	7" (178 mm) TFT Color LCD Touch Screen	Mono Keypad	Mono Keypad
Dose Duration	5.5 to 1000 ms (0.1 ms intervals)	15 to 1000 ms (1 ms intervals)	20 to 1000 ms (1 ms intervals)
Encoder Compatible	✓		
Maximum Discrete Dosing (cpm) (cph)	2000* (120,000)	500 (30,000)	150 (9,000)
MicroDose™ Technology	✓		
Line Speed Auto Detect	✓		
Electronic Dose Targeting	✓	✓	
Fixed Delay Mode	✓	✓	✓
Speed Compensated Mode	✓	✓	
Accuracy	± 2% of dose weight	± 5% of dose weight	± 5% of dose weight
Multiple Languages	✓		
RemoteDose™ Capable	✓		
IntelliDose™ Capable	✓		
Recipe Storage	✓		
Certifications	CE, NEMA 4X	CE, NEMA 4X	CE, NEMA 4X

* Results obtained under specific conditions.

Your Local Representative



Chart Inc.

46441 Landing Parkway • Fremont, CA 94538

Phone +1 800.371.3303 • Fax +1 408.577.1567 • Service +1 408.371.4932

www.chartdosers.com

© 2015 Chart Inc.

PN 20595537